

TECHNICAL BULLETIN NO. 20

June 2006

-
- 20.1 PREVIOUS TECHNICAL BULLETINS
 - 20.2 UPDATES TO AUTOCAD STANDARDS AND UDACS
 - 20.3 COATING ON APPURTENANCES IN VAULTS
 - 20.4 INSPECTION RESULTS AVAILABLE ON-LINE FOR DEVELOPMENT INSPECTIONS
 - 20.5 SCHEDULING INSPECTIONS
 - 20.6 FLUSHING OF MAINS
 - 20.7 CALL BEFORE YOU DIG
-

20.1 PREVIOUS TECHNICAL BULLETINS

Copies of all previous Technical Bulletins may be obtained at the following website:

http://www.lvwd.com/html/eng_tech_bulletins.html

20.2 UPDATES TO AUTOCAD STANDARDS AND UDACS

Modifications have been made to AutoCAD Standard PL11-1, *Thrust Block Installation*, (UDACS Plate No. 5) and AutoCAD Standard PL11-2, *Anchor Block Details for Reducers and Gate Valves*, (UDACS Plate No.3) to better illustrate actual field conditions of most installations. Please see attached updates.

20.3 COATING ON APPURTENANCES IN VAULTS

Backflow assemblies and other appurtenances in vaults must have an acceptable factory coating. If the coating is damaged prior to final acceptance, repairs must be made per specifications (or UDACS Section 3.15). Touch-up of factory coatings must be done with colors that match the original factory coating or the entire assembly must be repainted. No bare ferrous materials will be accepted.

20.4 INSPECTION RESULTS AVAILABLE ON-LINE FOR DEVELOPMENT INSPECTIONS

Inspection results for development services are now available on-line. Access this by going to http://www.lvvwd.com/html/eng_inspections.html. If you are not registered, you may register at http://www.lvvwd.com/cfml/insp_results/contact.cfml or call 258-7171 to get a username and password.

20.5 SCHEDULING INSPECTIONS

Considerable inspection time is spent on revisits to projects because of inspection failures or work that is not complete at the scheduled inspection time. In an effort to better serve contractors in a timely manner for construction inspections on both contract and development projects, please assist us in making the most efficient use of the inspector's time.

Before scheduling underground inspections:

- Verify all facilities have been installed in accordance with the approved drawings and specifications (or UDACS).
- Verify all piping and appurtenances are properly coated and wrapped.
- Verify reinforcements are placed in thrust and anchor blocks.
- Verify thrust and anchor blocks sizes comply with contract documents (or Standard Plate Nos. 3 and 5 of the UDACS).
- Verify joint deflection does not exceed specifications (or UDACS).

Preliminary checks prior to scheduling pressure testing and disinfection of mains will also eliminate failures.

Before scheduling Inspection for Pressure testing: (200 psi test for 2 hours)

- Isolate the newly installed system from the existing potable water system.
- Pressurize the newly installed system to ensure it holds test pressure and purge air from the system (any repairs must be left open for inspection).
- Open all valves on the system to be tested to ensure the entire system is being tested.
- System should be at the test pressure at the time the inspector is scheduled to arrive.

Before scheduling inspection for start of chlorine test period: (start chlorine contact period at 50 ppm and end 24 hours later with 10ppm minimum)

- Verify the chlorinated mains are isolated from the potable water system and inform all workers onsite not to open or close any valves.
- Mix chlorine to 50 ppm and pump the solution into the system (solution feeding is the only approved method for LVVWD system).

LVVWD Technical Bulletin No. 20
June 2006

- Check extremities of mains to ensure chlorinated water is dispersed throughout the entire system.
- Inform all persons onsite not to use the water system. This would cause a drop in the chlorine residual and result in the 24-hour contact test failing.
- It would be to the contractor's advantage to purchase inexpensive chlorine test kits to prevent failures.

Before scheduling inspections for final acceptance:

- Verify all underground inspections, pressure testing, disinfection, and health sampling has passed LVVWD inspection.
- Review the approved project plans and ensure all appurtenances have been installed and all backflow assemblies tested and passed.
- Verify all existing and new valves and blow-offs are raised, accessible, and collared and that meter boxes have concrete collars per the contract (or UDACS).
- Verify all valves are in the appropriate operating position, fire hydrants properly flow and weep, and that blow-offs flow.
- Schedule final inspection. The inspector will walk the project with the representative, verify valves are in the proper position, fire hydrants flow and weep, and blow-offs are flowed in their presence.
- Locator balls are placed as shown in contract documents (or UDACS Plate No. 27). District inspectors will verify locator balls for their location and ensure their proper operation. In the event the inspector cannot detect a locator ball, the contractor will be required to excavate and install or reinstall the locator ball.

20.6 FLUSHING OF MAINS

The contractor is required to dechlorinate all discharged water with a volume exceeding 5,000 gallons, including system water, to a chlorine level less than 0.1 mg/l and complete the Field Discharge Report and file it with the District. Although, in general, contractors have done a fairly good job of treating superchlorinated discharges, some contractors have been lax in treating normal system water. This also applies to fire hydrant flow tests.

20.7 CALL BEFORE YOU DIG

It is the contractor's responsibility to 'Call Before You Dig' and to preserve the utility location marks once they are made.

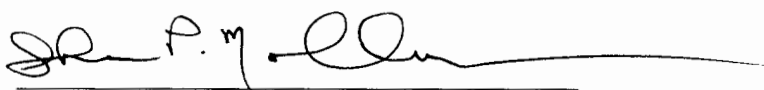

Director of LVVWD Engineering

June 1, 2006

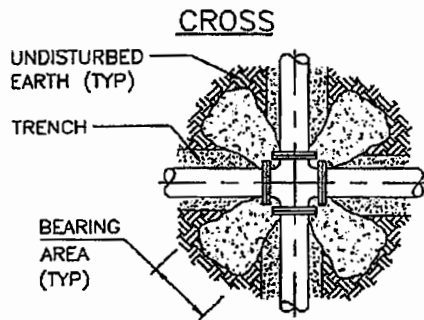

(FIGURE 1)

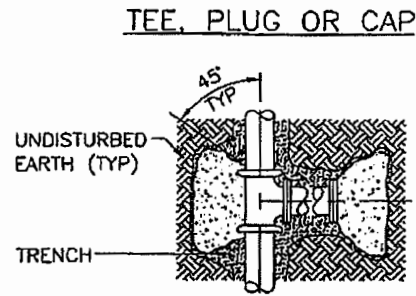

(FIGURE 2)

HORIZONTAL OR UPWARD VERTICAL BEND

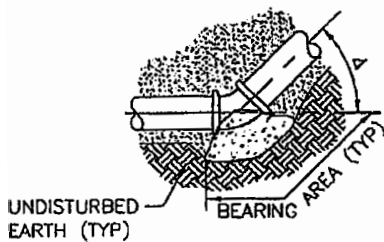

(FIGURE 3)

DOWNWARD VERTICAL BEND

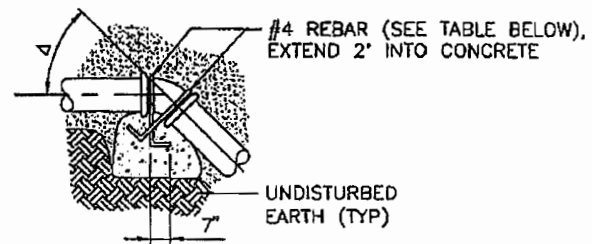

(FIGURE 4)

NOTE:

COAT AND WRAP ALL METAL SURFACES IN ACCORDANCE WITH SECTION 09965 OF THE LVWD SPECS, PROTECTIVE COATINGS. ALL CONCRETE SHALL BE 3000 PSI MINIMUM, 28 DAYS COMPRESSIVE STRENGTH. CONCRETE IS TO BE PLACED AGAINST UNDISTURBED EARTH. TABLE BELOW DENOTES MINIMUM BEARING AREA OR VOLUME OF THRUST BLOCK. SPECIAL DESIGN CALCULATIONS ARE TO BE SUBMITTED TO LVWD FOR APPROVAL IF ALLOWABLE SOIL BEARING CAPACITY IS LESS THAN 3000 PSF. ALL VERTICAL SURFACES NOT BEARING AGAINST UNDISTURBED EARTH SHALL BE FORMED.

PIPE ID	BEARING AREA IN SQ FT						CONC/CU YDS		
	FIGURE 1	FIGURE 2	FIGURE 3, Δ				FIGURE 4, Δ		
			90°	45°	22½°	11¼°	45°	22½°	11¼°
4"	2	2	2	2	1	1	1.0	0.5	0.5
6"	2	3	4	2	1	1	1.5	1.0	0.5
8"	3	5	7	4	2	1	3.0	1.5	1.0
10"	4	8	11	6	3	2	4.0	2.5	1.5
12"	6	11	15	8	4	2	6.0	3.0	1.5
16"	10	20	28	15	8	4	10.5 *	6.0	3.0
18"	13	25	35	19	10	5	13.5 *	7.5	3.5
20"	16	31	44	24	12	6	16.0 **	9.0	4.5
24"	22	44	63	34	17	9	23.5 **	12.5 *	6.5

* #5 REBAR ** #6 REBAR

NOTE:

USE OF THRUST BLOCKS FOR PIPE DIAMETERS GREATER THAN 12" REQUIRES PRIOR DISTRICT APPROVAL AND WILL BE EVALUATED ON A CASE BY CASE BASIS.

THRUST BLOCK INSTALLATION

NOT TO SCALE

PL11-1 030206



LEGEND: d = LARGER DIAMETER PIPE SIZE

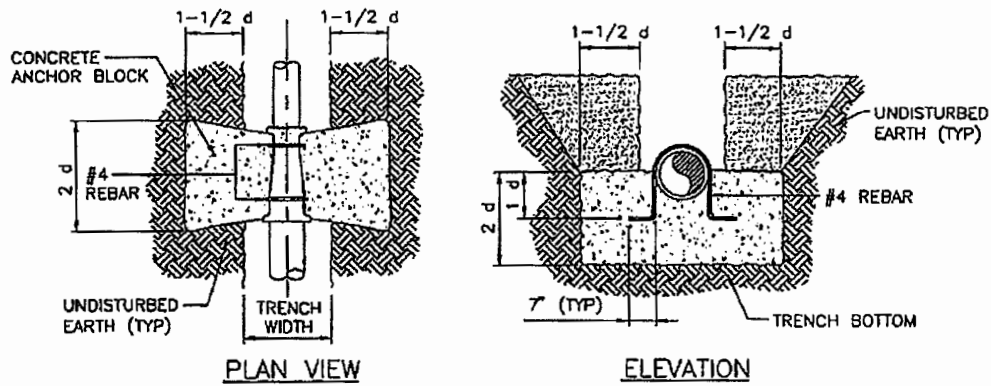

IN-LINE REDUCERS

LEGEND: d = NOMINAL PIPE SIZE

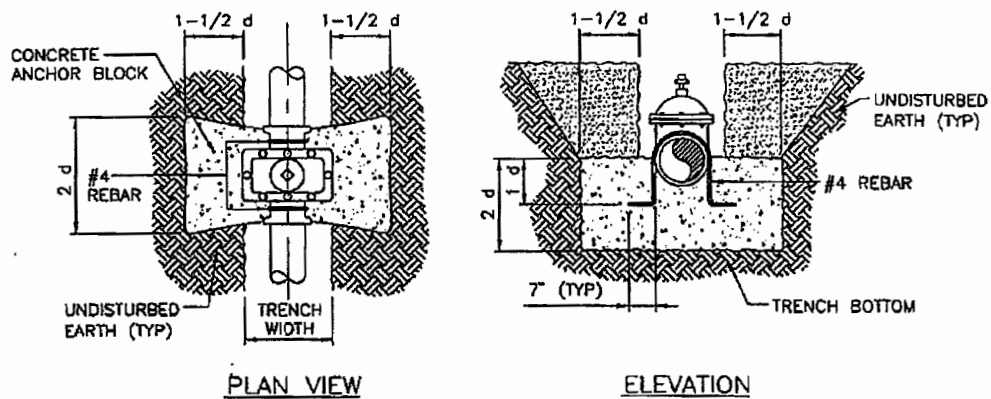

IN-LINE GATE VALVES

LEGEND: d = NOMINAL PIPE SIZE

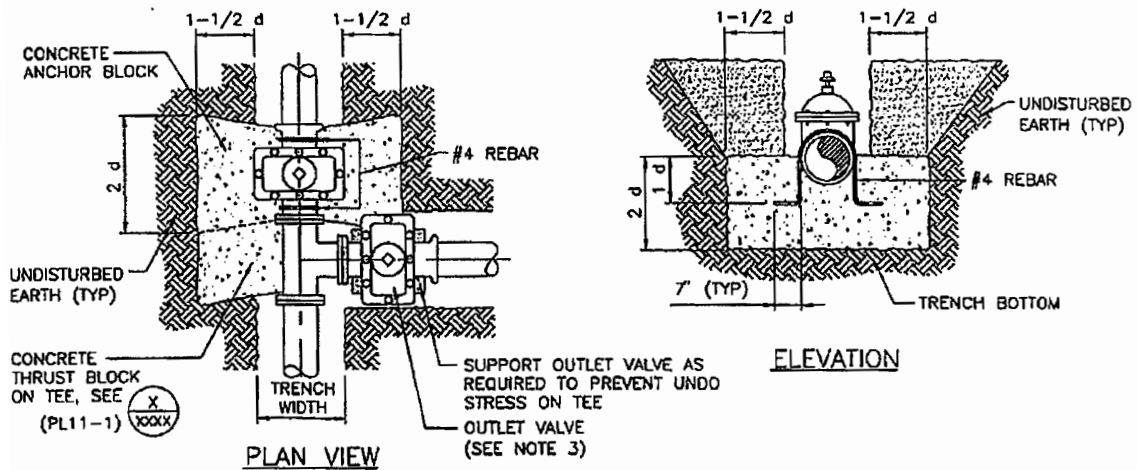

TEE GATE VALVES

NOTES:

1. ALL CONCRETE SHALL BE 3000 PSI MINIMUM 28 DAYS COMPRESSIVE STRENGTH
2. ALL VALVES AND EXPOSED REBAR TO BE COATED AND WRAPPED IN ACCORDANCE WITH SECTION 09965 OF THE LWWWD SPECS, PROTECTIVE COATINGS.
3. WHEN PIPE IS INSTALLED BETWEEN TEE AND OUTLET VALVE AN ADDITIONAL CONCRETE ANCHOR BLOCK WILL BE REQUIRED ON THE OUTLET VALVE.

ANCHOR BLOCK DETAILS FOR REDUCERS AND GATE VALVES

NOT TO SCALE

PL11-2 030206

